

TRITON

ELINA
*inclusive concentric exposed
thermostatic mixer valve*

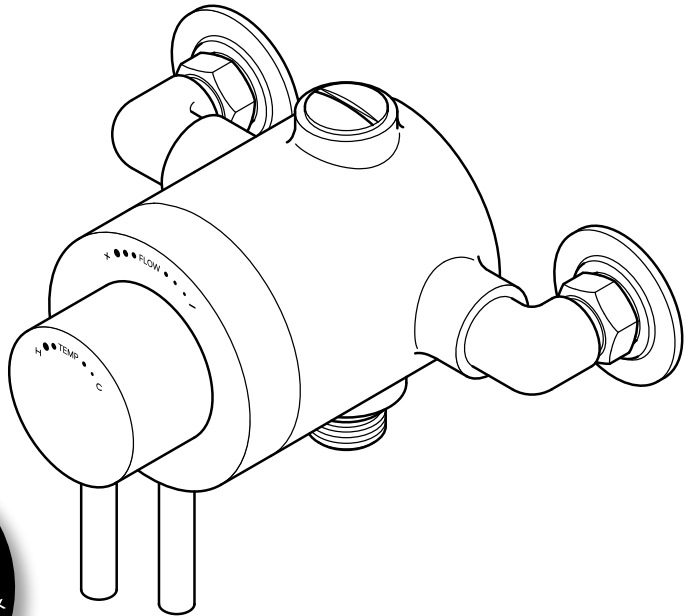

86004540



**Installation and
operating instructions**



The showerhead and hose supplied with this product are a safety critical part of your shower. Failure to use genuine Triton parts may cause injury and invalidate your guarantee.



CONTENTS	Page
MAIN COMPONENTS.....	1
INTRODUCTION.....	2
SITE REQUIREMENTS	2
SAFETY WARNINGS	2
PLUMBING REQUIREMENTS	3
WATER SYSTEM REQUIREMENTS.....	3
TYPICAL COMMERCIAL INSTALLATIONS.....	4
INSTALLATION.....	5
FITTING THE MIXER.....	6
ANTI-SCALD PROTECTION	7
Recommended outlet temperatures - TMV	7
LEAK TESTING	7
COMMISSIONING - TMV3	8
ADJUSTING THE MAXIMUM TEMPERATURE SETTING	9
OPERATING THE SHOWER.....	10
APPROVALS	11
FLOW CHART	11
DIMENSIONS	12
SPARE PARTS.....	13
IN SERVICE TESTING/FREQUENCY OF TESTING - TMV3	14 - 15
CLEANING.....	16
FAULT FINDING.....	17 - 18
TEST RECORD.....	19
Guarantee, service policy, etc.....	rear cover

INSTALLERS PLEASE NOTE THESE INSTRUCTIONS ARE TO BE LEFT WITH THE USER

To check the product suitability for commercial and multiple installations, please contact Triton's specification advisory service before installation. Please see back off book for contact information.

MAIN COMPONENTS

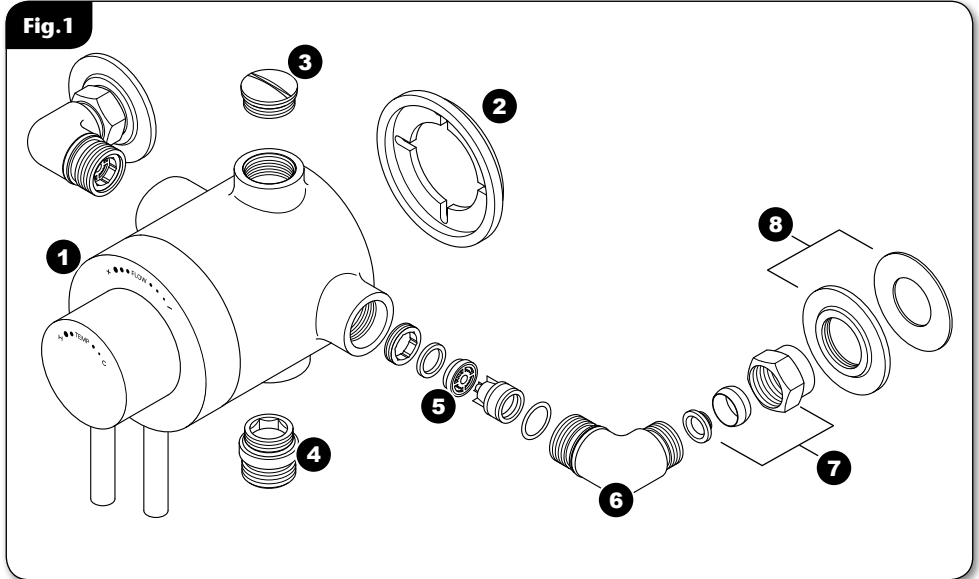

Ref. Description

- | | |
|----------------------|---------------------------|
| 1. Mixer shower body | 6. Elbow X2 |
| 2. Mounting plate | 7. Inlet nut and Olive X2 |
| 3. Blanking plug | 8. Trim and Seal X2 |
| 4. Outlet adapter | |
| 5. Flow regulator X2 | |

All dimensions listed in this fitting book regarding the product and installation are approximate.

*All kits are for illustration purposes only and are not supplied unless otherwise stated.

INTRODUCTION

This book contains all the necessary fitting and operating instructions for your mixer shower. Please read them carefully and read through the whole of this book before beginning your installation.

The shower installation must be carried out by a suitably competent person and in sequence of this instruction book.

Care taken during the installation will give a long and trouble free life from your mixer shower.

SITE REQUIREMENTS

The installation must be in accordance with Water Regulations and Bylaws. Valves operating outside these conditions of use cannot be guaranteed to operate as Type 3 valves.

Water pressure requirements

Running water pressure:

Gravity fed (LP)	- 0.2 bar min. 1.0 bar max.
Mains fed (HP)	- 1.0 bar min. 5.0 bar max.

Maximum static water pressure:

Gravity and mains	- 10 bar
-------------------	----------

This mixer shower is designed for use with traditional low pressure 'gravity' water systems, using a cold water cistern and hot water cylinder as well as for the higher pressure systems found in the UK up to a maximum of 5 bar running pressure.

For effective operation of the internal seals, the maximum static pressure must not be exceeded.

Pressure reducing valve

On sites where the running pressure is above 5 bar, the use of a suitably sized pressure reducing valve fitted in the cold mains supply pipe work can provide nominally equal pressures at the mixer shower.

Replacement parts can be ordered from Triton Customer Service. See 'spare parts' for details and part numbers.

Water minimum flow rate

For best performance within the specified running pressure range a minimum flow of 8 litres per minute should be available to both inlets.

Water temperature requirements

Maximum hot water temperature:	= 80°C
TMV3 Recommended maximum:	= 65°C
Minimum hot water temperature:	= 52°C
Maximum cold water temperature:	= 20°C
Minimum cold water temperature:	= 5°C
Minimum temperature differential:	= 10°C

The mixer shower **MUST NOT** be subjected to water temperatures above 80°C.

BS 6700 recommends that the temperature of stored water should never exceed 65°C.

A stored water temperature of 60°C is considered sufficient to meet all normal requirements and will minimise the effects of scale in hard water areas.

Water temperature adjustment and thermal safety

The mixed water temperature can be adjusted from cold through to a top limit which must be preset during installation with full anti-scald protection throughout the range (35°C to 40°C) providing the hot water temperature at the inlet remains 10°C above the outlet temperature.

Should there be a loss of flow to either incoming supply then- water from the shower will stop or be reduced until both supplies are restored.

SAFETY WARNINGS

- DO NOT** choose a position where the shower could become frozen.
- DO NOT** connect this mixer shower to any form of tap or fitting not recommended by the manufacturer.
- DO NOT** allow the inlet pressure or flow rates to operate outside the guidelines laid out in 'site requirements'.
- DO NOT** connect the mixer shower to a gravity hot supply and a mains cold supply (or vice versa).

PLUMBING REQUIREMENTS

DO NOT use jointing compounds on any pipe fittings for the installation,

DO NOT solder fittings near the mixer unit as heat can transfer along the pipework and damage the mixer valve.

IMPORTANT:

- The layout and sizing of pipework **MUST** be such that nominally equal inlet supply pressures are achieved and the effects of other draw-offs are minimised.
- The pipe-work should be installed such that other taps and appliances being operated elsewhere on the premises do not significantly affect the flow.
- When connecting pipe-work avoid using tight 90° elbows; swept or formed bends will give the best performance.
- The hot water pipe entry **MUST** be made to the left-hand side inlet, marked **HOT, 'H'** or with a **red/orange label**.
- Suitable isolating valves (complying with Water Regulations and Bylaws) **MUST** be fitted on the hot and cold water supplies to the shower as an independent means of isolating the water supplies should maintenance or servicing be necessary.
- Suitable backflow prevention devices **MUST** be installed with this product in accordance with the water supply (water fittings) Regulations 1999.
- It is preferable to flush the pipe-work to clear the system of debris and check for leaks before connecting to the mixer.
- The mixer inlets contain removable filters that may become blocked if debris is not flushed through before fitting.

(Commercial applications)

- It is recommended for all commercial applications that easily accessible in-line filters are used to aid maintenance.

Hard water areas

- a. If it is intended to operate the shower in areas of hard water (above 200-ppm temporary hardness), a scale inhibitor may have to be fitted. For advice on the scale inhibitor, please contact Customer Service.
- b. For best performance the showerhead **MUST** be regularly cleaned to remove scale and debris.

WATER SYSTEM REQUIREMENTS

This mixer shower is suitable for:

- Gravity water systems
- Pumped gravity systems
- Fully modulating type combination boilers
- Multi-point hot water heaters
- Thermal storage
- Unvented systems

NOTE: *When installing this mixer with a Combination or multi-point boiler, it may be necessary to install flow regulation.*

Check that the appliance is capable of delivering hot water at a minimum switch-on flow rate of 3 litres per minute. At flow rates between 3 and 8 litres per minute, the appliance must be capable of raising the water temperature to 52°C (minimum).

Water temperature at the inlet of the mixer valve must remain relatively constant when flow rate adjustments are made (refer to the appliance-operating manual to confirm compatibility with this mixer shower).

Where thermal store systems and instantaneous gas water heaters are used, if excessive draw-off take place the appliance may not be able to maintain an adequate output temperature. This could result in the shower temperature becoming noticeably cooler.

Flow regulators can be fitted with high-pressure water systems to reduce flow rate and assist economy.

The hot supply temperature **MUST remain a minimum of 10°C hotter** than the required blend temperature for optimum performance.

*Fig.2

*(diagrammatic view – not to scale)

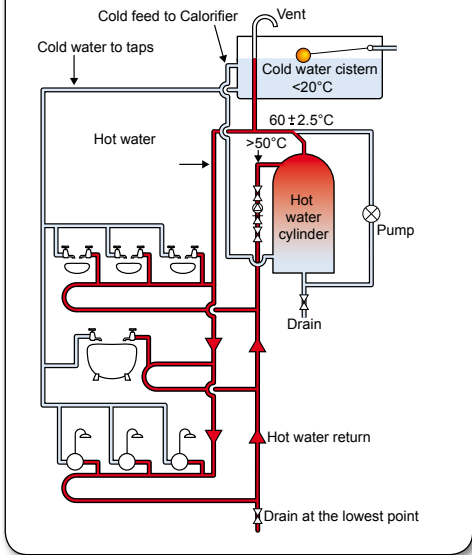

TYPICAL COMMERCIAL INSTALLATIONS

Commercial gravity fed systems (fig.2)

The shower control **MUST** be fed from a cold water cistern and hot water cylinder providing nominally equal pressures. There **MUST** be a minimum of one metre head of water.

The minimum head distance is measured from the base of the cold water cistern to top of the showerhead. If water supply is fed by gravity then supply pressure should be verified.

Commercial unvented mains pressure systems (fig.3)

The shower control can be installed with an unvented, stored hot water cylinder.

For systems with no cold water take off after the appliance-reducing valve, it will be necessary to fit an additional drop tight pressure-reducing valve when the mains pressure is over 5 bar. The drop tight pressure reducing valve **MUST** be set at the same value as the unvented package pressure reducing valve.

NOTE: An additional expansion vessel may be required if a second pressure-reducing valve is installed. This does not apply to packages with a cold take off after the pressure-reducing valve to the cylinder.

*Fig.3

*(diagrammatic view – not to scale)

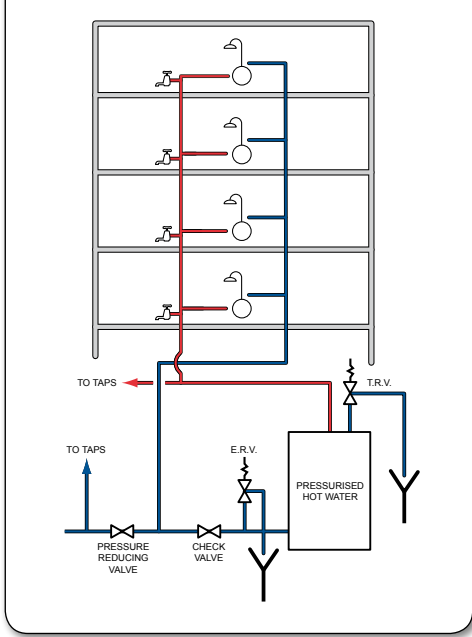

*(kits are for illustration purposes only)

INSTALLATION

Preparing the mixer valve

Check the contents to make sure all parts are present.

Before starting the mixer installation, make sure all the openings on the valve are carefully covered to stop ingress of any debris, etc. while routing the supply pipework.

The shower valve is suitable for:

- built-in installation in a solid wall
- a stud partition wall
- a dry lined wall
- fixing to a shower cubicle or panel.

Siting of the shower and accessories

Refer to (fig.4) for correct siting of the shower.

The mixer valve should be positioned, as detailed, with all controls within comfortable reached of the user.

The accessories (showerhead, riser rail and/or fixed showerhead) can be positioned above or to either side of the shower, refer to (fig.4).

Supply pipe work

Complete the pipework to the shower area having decided on the position of the shower and direction of pipe entry (for example rising, falling or rear entry)

The hot and cold water pipes should not be permanently attached to the wall within one metre of the valve, before installation is complete, to allow for final adjustment of the valve position.

Rear entry supplies

Using a spirit level, mark the route of incoming hot and cold water supply pipes at a distance of 150mm (approximately) between centres (fig.5).

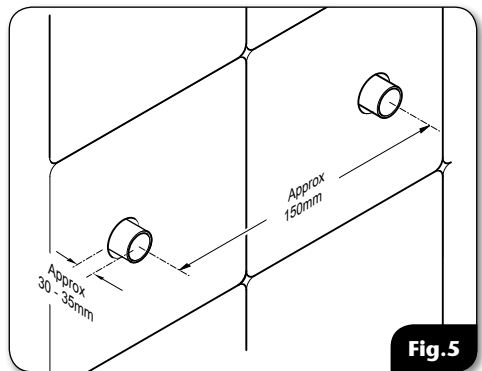
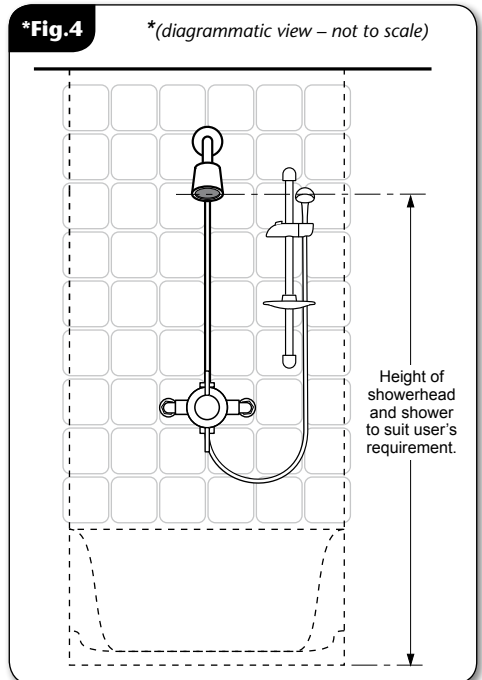
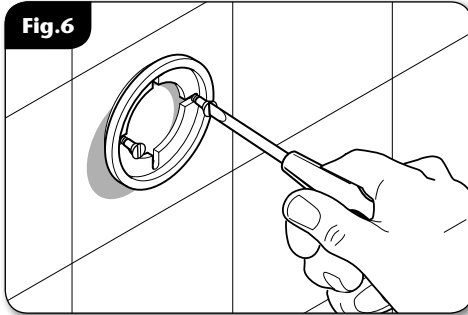

Fig.5

*(kits are for illustration purposes only)



FITTING THE MIXER

Mark the position of the four locating screws for the mounting plate, although if installing to a solid brick wall using two diagonal holes will usually be enough.

Drill and plug the holes using the wall plugs provided. (The wall plugs provided are suitable for most brick walls — use an appropriate masonry drill, but if the wall is plasterboard or a soft building block, use special wall plugs and a suitable drill bit).

Fit the mounting plate onto the wall using the screws supplied (**fig.6**).

The inlet elbows allow for either rising, falling or rear entry hot and cold water supplies. The elbows have 'O' ring seals (**fig.7**) to the body and do not require PTFE tape or other means of sealing.

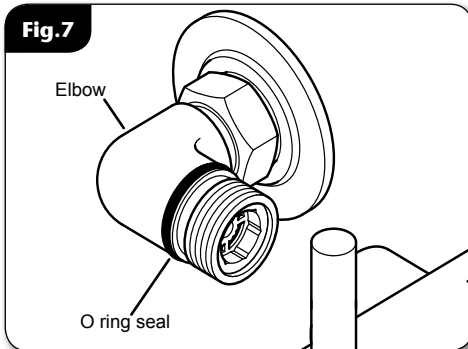

IMPORTANT: Make sure that all supply pipework has been flushed through before fitting the mixer (**fig.8**).

Fit the trim onto the inlet water pipes followed by the nut and olive (**fig.9**).

Connect the hot water supply to the inlet marked **HOT, 'H'** or red/orange label and connect the cold water supply to the inlet marked **COLD, 'C'** or blue label (**fig.9**).

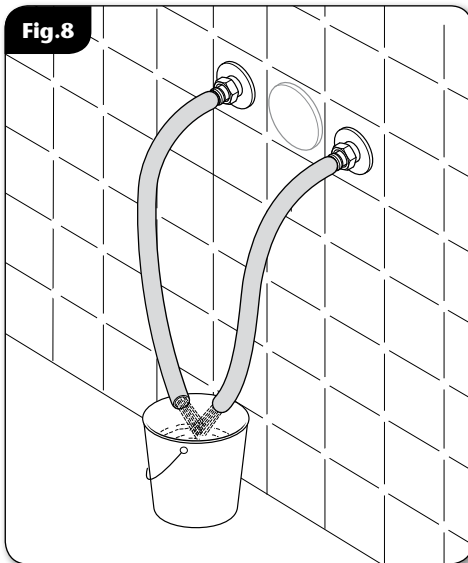

Tighten all compression fittings

Tighten all the grub screws to secure the mixer to mounting plate.

Outlet adapter and plug

The outlet adapter and plug can be repositioned dependant on the outlet required (top or bottom).

Flow regulation

A flow regulator is supplied for use with high-pressure water systems and may be fitted with any of the systems listed to reduce flow rate and assist economy.

Concentric exposed thermostatic mixer valve

To fit the flow regulators

- Unscrew the elbows from the mixer.
- Remove the internal retaining nut.
- Fit the flow regulator.
- Refit the internal retaining nut and elbows.

Please note the flow regulator is only designed to work in one direction (fig.10).

ANTI-SCALD PROTECTION

It is important that the mixer valve is tested regularly to prevent the risk of scalding and guarantee user safety. This can be carried out as follows: with the mixer blend temperature set at 38°C isolate the cold water supply. The outlet flow rate will reduce to a safe level.

Recommended outlet temperatures

The **BuildCert TMV** scheme recommends the following set maximum mixed water outlet temperatures for use in all premises:

44°C - for bath fill but see notes below.

41°C - for showers.

41°C - for washbasins.

38°C - for bidets.

The mixed water temperatures must never exceed **46°C** at terminal fitting.

The British Burns Association recommends **37** to **37.5°C** as a comfortable bathing temperature for children. In premises covered by the Care Standards Act 2000, the maximum mixed water outlet temperature is **43°C**.

LEAK TESTING

Direct the outlet of the mixer to waste. Open the isolating valves to the shower and check for leaks. Remedy any leaks found.

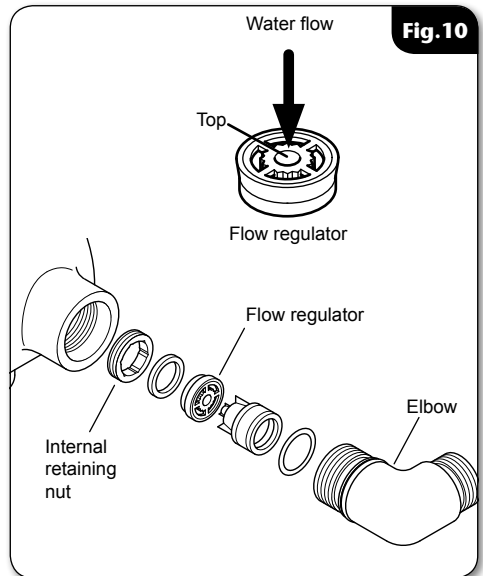
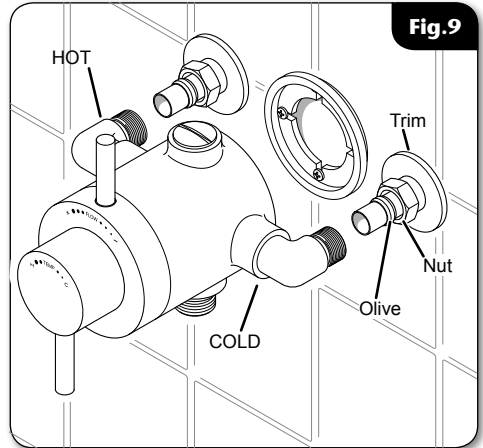

COMMISSIONING (TMV3)

The following conforms to **NHS Estates Model Engineering Specification D08** for when the mixer has been installed in healthcare premises.

Important: Make sure that all supply pipework has been flushed through before commissioning.

The maximum temperature should not exceed 41°C.

Start the water flow by rotating the flow control.

Make sure that both the hot and cold water supplies are fully open and at (or near to) their design temperature and pressures, and are within the requirements as stated.

Make sure the temperature control is at the maximum temperature setting.

Allow the shower to run at the maximum temperature setting until the water temperature has stabilised. Rotate the temperature control until your desired maximum showering temperature is reached.

The mixer has a temperature stop to prevent accidental rotation to higher temperatures. This is adjustable to provide a maximum temperature of 41°C and should be checked on site to guarantee user safety.

After setting the maximum temperature, turn the shower on and off several times and check the maximum setting is correct. Record the commissioning data on the maintenance record at the rear of this book in order for the in-service performance of the mixer valve to be assessed.

Finally, check the thermal shut off facility of the valve by performing a thermal shut off test. Shut off the cold supply.

The flow from the shower should stop immediately or reduce to a trickle in which case the water temperature should be less than 43°C.

In either case there is no risk of scalding.

If, however, the temperature is above 43°C then it is likely there is contamination in the valve stopping it from shutting off the hot supply. In this case refer to the maintenance section or contact Customer Service.

In domestic installations where D08 specification is not required, the maximum temperature setting should not exceed 46°C.

Temperature adjustment range

The mixed water temperature can be adjusted from cold through to a top limit (which can be pre-set during installation – factory set at approximately 38°C) with full anti-scald protection throughout the range.

ADJUSTING THE MAXIMUM TEMPERATURE SETTING (and fitting the levers)

NOTE: Due to varying site conditions it is advised that the valves maximum temperature be set on site (to around 38°C) once the mixer has been installed and commissioned using a calibrated thermometer.

- The levers are supplied loose in the box.
- To adjust the maximum temperature setting remove the temperature control using a suitable allen key. Allow the water to run until the temperature has stabilised. Adjust the temperature control spindle by hand **(fig.11)**.
- When the showering temperature is satisfactory turn off the shower.
- Refit the temperature knob, making sure the maximum temperature stop pin is as close to the over ride stop face as possible **(fig.12)**.
- Secure in place with the retaining grub screw and fit the levers.

NOTE: If "Tamper proof" lever fitting is required, tighten the levers into the controls using a suitable Allen key placed into the recessed 'hex' end of the lever.

DO NOT OVERTIGHTEN THE LEVER.

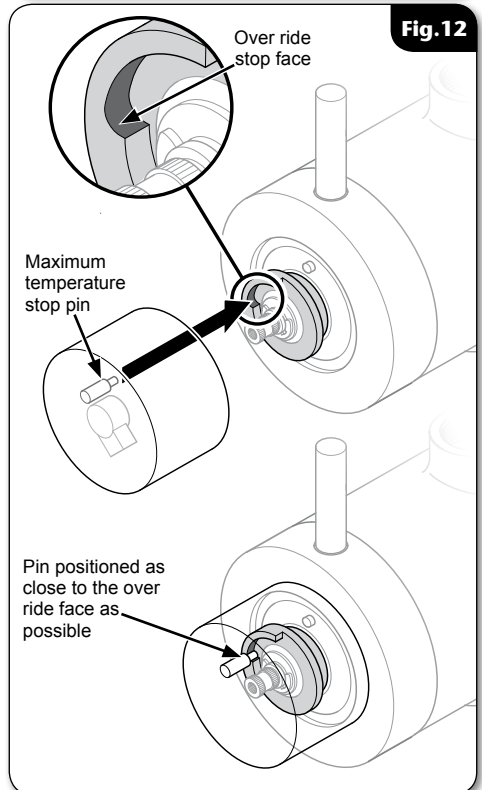
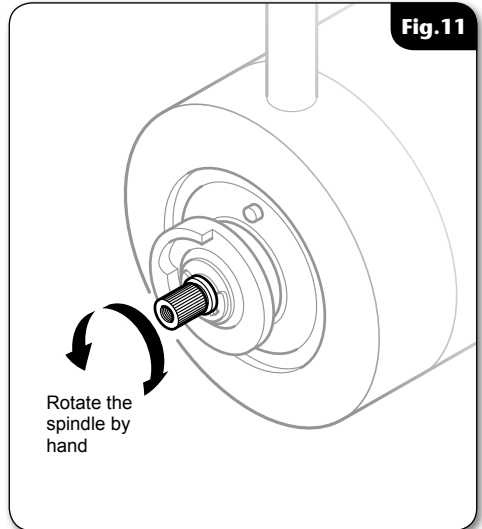
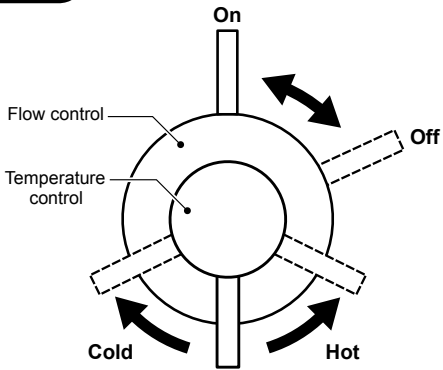

Fig.13



OPERATING THE SHOWER (fig.13)

To start the shower, turn the On/Off flow control fully anti-clockwise for maximum flow.

To stop the shower, turn the On/Off flow control fully clockwise.

To adjust the showering temperature rotate the temperature control — clockwise for cooler and anti-clockwise for hotter.

CAUTION: *Exposed metal surfaces may become hot during use.*

APPROVALS

This mixer valve has been designed to comply with the requirements of: **WRAS**
TMV3 HP-S

DESIGNATION

This valve has been approved for the following designations: **HP-S High Pressure Shower**

MARKING

The unique reference for this product is: **86004540**
This can be found, laser marked onto the body of the mixer valve.

FLOW CHART

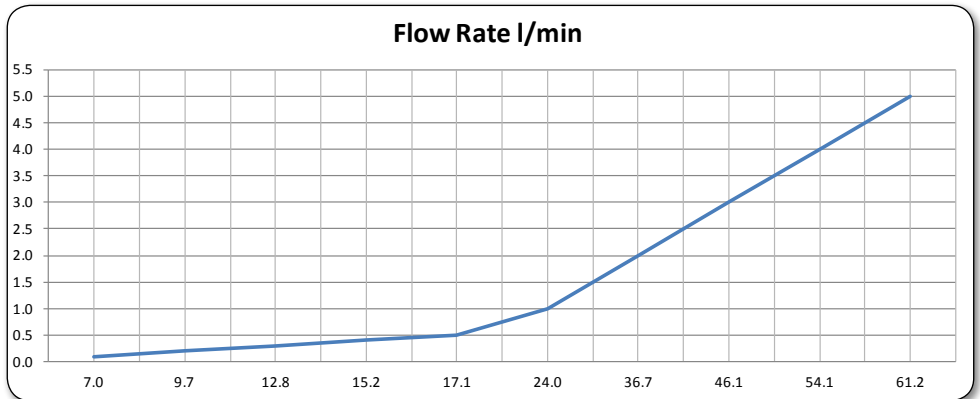

- Flow rate at 38°C
- Flow control fully open
- Open outlet
- No flow regulator fitted

DIMENSIONS

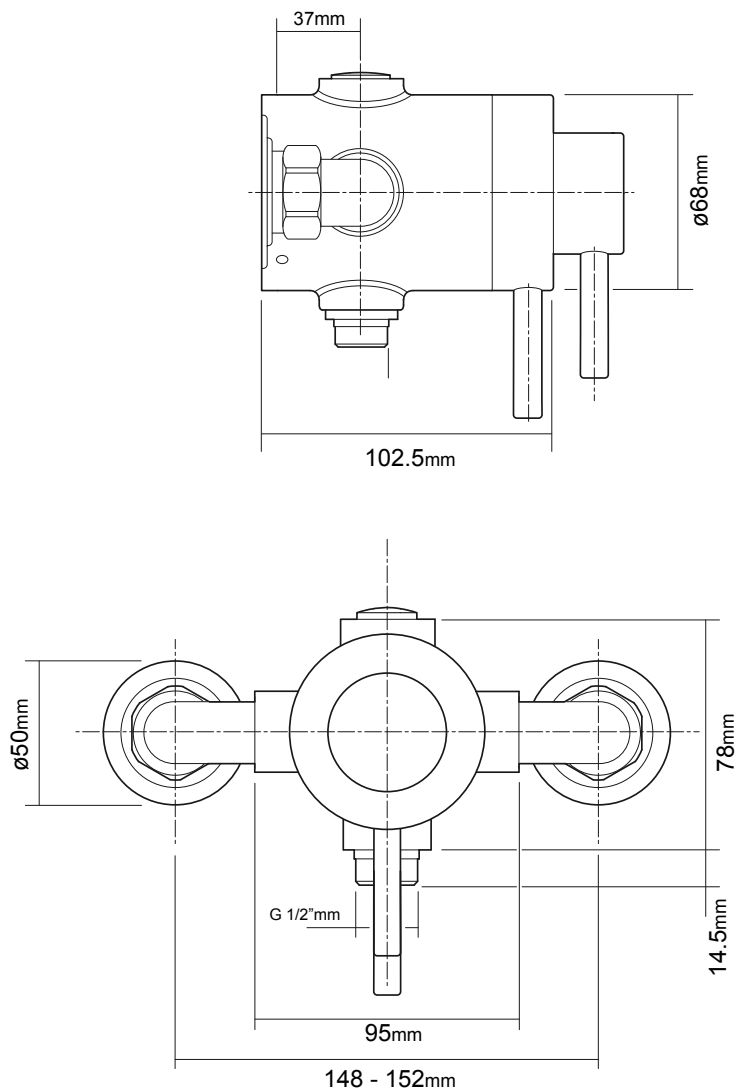

All dimensions listed in this fitting book regarding the product and installation are approximate.

SPARE PARTS

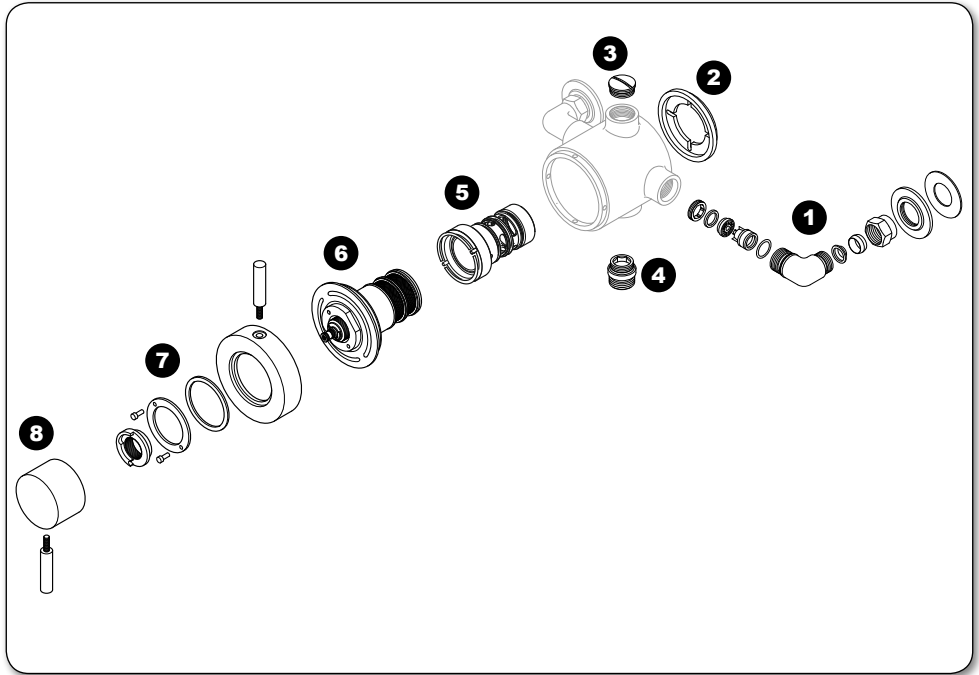

Ref.	Description	Part No.
1.	Elbows Assembly	83315650
2.	Wall Bracket	83312970
3.	Outlet Plug	83315630
4.	Outlet Connector	83315640
5.	Flow Control Assembly	83315620
6.	Thermostatic Cartridge Assembly	83315610
7.	Flow Knob Assembly	83315580
8.	Temperature Knob Assembly	83315570

IN SERVICE TESTING

Maintenance of the unit is required to give continued performance after installation and that it continues to provide scald prevention.

Note: A thermostatic mixing valve in need of maintenance can be undetectable in normal use and only becomes apparent when a disruption occurs in the hot or cold water supply temperatures or pressures.

Purpose

The purpose of in-service tests is to regularly monitor and record the performance of the thermostatic mixing valve. Deterioration in performance can indicate the need for service work on the valve and/or the water supplies.

Procedure

Using the same measuring equipment or equipment to the same specification as used in the commissioning of the valve, adjust the temperature of the mixed water in accordance with the manufacturer's instructions and the requirement of the application. Carry out the following sequence:

- a) record the temperature of the hot and cold water supplies
- b) record the temperature of the mixed water at the largest draw-off flow rate
- c) record the temperature of the mixed water at a smaller draw-off flow rate, which shall be measured

If the mixed water temperature has changed significantly from the previous test results (e.g. > 1 K / 5), record the change and before re-adjusting the mixed water temperature check:

- a) that any in-line or integral strainers are clean
- b) any in-line or integral check valves or other anti-back siphonage devices are in good working order
- c) any isolating valves are fully open

With an acceptable mixed water temperature, complete the following procedure:

- a) record the temperature of the hot and cold water supplies
- b) record the temperature of the mixed water at the largest draw-off flow rate
- c) record the temperature of the mixed water at a smaller draw-off flow rate, which shall be measured
- d) isolate the cold water supply to the mixing valve and monitor the mixed water temperature
- e) record the maximum temperature achieved as a result of (d) and the final stabilised temperature
- f) record the equipment, thermometer etc. used for the measurements

If at step (e) the final mixed water temperature is greater than the values in Table 17 and / or the maximum temperature exceeds the corresponding value from the previous results by more than about 2 K, the need for service work is indicated

NOTE: In-service tests should be carried out with a frequency, which identifies a need for service work before an unsafe water temperature can result. In the absence of any other instruction or guidance, the procedure described in Annex F of D 08 may be used

Annex F of D 08 (informative)

FREQUENCY OF IN-SERVICE TESTS

General

In the absence of any other instruction or guidance on the means of determining the appropriate frequency of in-service testing, the following procedure may be used:

- a) 6 to 8 weeks after commissioning carry out the tests detailed in

“In-Service Tests”

- b) 12 to 15 weeks after commissioning carry out the tests detailed in

“In-Service Tests”

Depending on the results of the above tests, several possibilities exist:

- a) If no significant changes (e.g. ≤ 1 K) in mixed water temperatures are recorded between commissioning and 6 to 8 week testing, or between commissioning and 12-15 week testing the next in-service test can be deferred to 24 to 28 weeks after commissioning.
- b) If small changes (e.g. 1 to 2 K) in mixed water temperatures are recorded in only one of these periods, necessitating adjustment of the mixed water temperature, then the next in-service test can be deferred to 24 to 28 weeks after commissioning.
- c) If small changes (e.g. 1 to 2 K) in mixed water temperatures are recorded in both of these periods, necessitating adjustment of the mixed water temperature, then the next in-service test should be carried out at 18 to 21 weeks after commissioning.
- d) If significant changes (e.g. > 2 K) in mixed water temperatures are recorded in either of these periods, necessitating service work, then the next in-service test should be carried out at 18 to 21 weeks after commissioning.

The general principle to be observed after the first 2 or 3 in-service tests is that the intervals of future tests should be set to those which previous tests have shown can be achieved with no more than a small change in mixed water temperature.

Note: A testing record page has been added to the back of the book for your use.

Cleaning

Triton recommends that all products are cleaned using warm, soapy water.

Do not use abrasive or aggressive chemical cleaning products as this may affect the product surface finish and invalidate your guarantee.

Cleaning the filters (fig.A)

It is advised that this should be carried out by a qualified person.

- Turn off the water supplies before starting.
- Remove Hot and Cold elbows.
- Remove the internal retaining nut and filter.
- Wash the filter thoroughly under running water, use a suitable brush to remove all debris.
- Reassemble the shower.

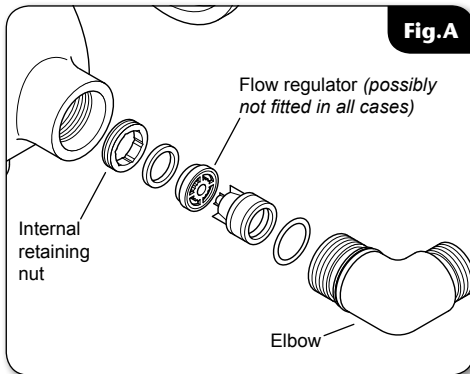

Disinfection

Where chlorine is used for the disinfection of water systems all relevant guidelines and approved codes of practice must be strictly followed. Failure to comply with the relevant guidelines and approved codes of practice may invalidate your guarantee.

WARNING!

DO NOT use 'powerful' abrasive or solvent cleaning fluids when cleaning the shower as they may damage the fittings.

FAULT FINDING

The following can be carried out by a competent person

Problem/Symptom	Cause	Action/Cure
1 Water too hot.	1.1 Temperature control incorrectly commissioned.	1.1.1 Refer to commissioning section.
	1.2 Not enough cold water flowing through shower.	1.2.1 Reposition the temperature control.
	1.3 Increase in the ambient cold water temperature.	1.3.1 Reposition the temperature control.
	1.4 Cold water supply blocked.	1.4.1 Turn off shower and consult a competent plumber or contact Customer Service.
	1.5 High volume of cold water drawn off elsewhere.	1.5.1 Reduce the simultaneous demand from the mains supply.
2 Water too cold.	2.1 Temperature control incorrectly commissioned.	2.1.1 Refer to commissioning section.
	2.2 Not enough hot water flowing through shower.	2.2.1 Reposition the temperature control
	2.3 Decrease in the ambient cold water temperature.	2.3.1 Reposition the temperature control
	2.4 Insufficient hot water supplies from the heating system.	2.4.1 Make sure heating appliance is set to maximum or has sufficient stored hot water. 2.4.2 Make sure heating appliance is igniting by trying a hot water tap elsewhere.
	2.5 Hot water supply blocked or restricted.	2.5.1 Turn off shower and consult a competent plumber or contact Customer Service.
3 High water flow and/or poor performance on a mains fed system.	3.1 Flow regulators not fitted.	3.1.1 Fit the supplied flow regulators in the inlet elbows (<i>see 'To fit a flow regulator' on page 7</i>).

FAULT FINDING

Problem/Symptom	Cause	Action/Cure
4 Water does not flow or shower pattern collapses when another outlet is turned on.	4.1 Water supplies cut off.	4.1.1 Check water elsewhere in house and if necessary contact local water company.
	4.2 Shower unit blocked.	4.2.1 Inspect the filters. Clean if necessary.
	4.3 Blockage in pipework.	4.3.1 Turn off the shower and consult a suitably competent plumber.
	4.4 Showerhead blocked.	4.4.1 Clean the showerhead.
	4.5 System not capable of supplying multiple outlets at the same time.	4.5.1 Reduce the simultaneous demand. 4.5.2 Make sure stop or service valve is fully open. 4.5.3 Check if there is sufficient water pressure.

The following is recommended for a professional qualified installer only

5 Water too cold.	5.1 Running pressure is excess of maximum recommended.	5.1.1 Fit a pressure reducing valve.
6 Shower controls noisy when in use.	6.1 Running pressure in excess of maximum recommended.	6.1.1 Fit a pressure reducing valve.
7 Shower will not shut off.	7.1. Pipework not flushed out before connecting to the unit. Internal components damaged.	7.1.1 Service valve.

COMMISSIONING, MAINTENANCE and IN-SERVICE TESTING RECORD

Where installed: _____

Mixer valve location: _____

Date installed: _____ Installed by: _____

Commissioning details: Hot water - Temp: _____ °C Pressure: _____ Bar
 Cold water - Temp: _____ °C Pressure: _____ Bar
 Maximum temperature setting - Temp: _____ °C Pressure: _____ Bar

Equipment used:

Inspection and maintenance record:

UK SERVICE POLICY

In the event of a product fault or complaint occurring, the following procedure should be followed:

1. Telephone Customer Service on **024 7637 2222** having available, your details including post code, the model number and power rating of the product, together with the date of purchase and, where applicable, details of the particular fault.
2. If required, the Customer Service Advisor will arrange for a qualified engineer to call.
3. All products attended to by a Triton service engineer must be installed in full accordance with the Triton installation guide applicable to the product. (Every product pack contains an installation guide, however, they can also be downloaded free at www.tritonshowers.co.uk).
4. Our engineer will require local parking and if a permit is required this must be available to the engineer on arrival at the call.
5. It is essential that you or an appointed representative (*who must be over 18 years of age*) is present for the duration of the service engineer's visit. If the product is in guarantee you must produce proof of purchase.
6. Where a call under the terms of guarantee has been booked and the failure is not product related (*i.e. scaling and furring, incorrect water pressure, pressure relief device operation or electrical/plumbing installation fault*) a charge will be made. A charge will also be issued if nobody is at home when the service engineer calls or adequate parking/permit is not available.
7. If the product is no longer covered by the guarantee an up front fixed fee will be charged before the site visit.
8. Should proof of purchase not be available on an "in-guarantee" call, or should the service engineer find that the product is no longer under guarantee, the engineer will charge the same fixed price and the customer will be expected to pay the engineer before he leaves. If payment is not made on the day an administration charge will be added to the fixed charge.
9. If a debt is outstanding from a previous visit, or from any other Triton purchase, Triton reserves the right to withhold service until the debt has been settled.
10. Triton takes the health, safety and wellbeing of its employees very seriously and expects customers to treat all staff members with respect. Should any employee feel threatened or receive abuse, either verbally or physically, Triton reserves the right to withhold service and will support the employee with a legal prosecution.

Replacement parts policy

1.1. It is the policy of Triton Showers to maintain parts availability for the duration of production and a period of 5 years thereafter in accordance with industry standards. Spare parts can be ordered via our online spare parts store, or by telephoning Triton Customer Service Spares Department on 024 7637 2222. Payment should be made by credit / debit card (excluding American Express or Diners Card). Payment can also be made by pre-payment of a pro-forma invoice, by cheque or postal order.

1.2. Telephone orders are based on information given during the call. Before contacting Triton, please verify your requirements using the information contained in the user guide. Triton cannot accept liability for incorrect part identification.

TRITON COMMERCIAL GUARANTEE

With the exception of accessories, Triton guarantee the product against all manufacturing defects for a period of **3 years** (from the date of purchase) provided that it has been installed by a competent person in full accordance with the fitting instructions.

All accessories such as shower heads, hoses and riser rails carry a **1 year** parts only guarantee against manufacturing defects.

Any part found to be defective during this guarantee period we undertake to repair or replace at our option without charge so long as it has been properly maintained and operated in accordance with the operating instructions, and has not been subject to misuse or damage.

This product must not be taken apart, modified or repaired except by a person authorised by Triton. This guarantee applies only to products installed within the United Kingdom and does not affect your statutory rights.

What is not covered:

1. Breakdown due to: **a)** use other than domestic use by you or your resident family; **b)** wilful act or neglect; **c)** any malfunction resulting from the incorrect use or quality of electricity, gas or water or incorrect setting of controls; **d)** failure to install in accordance with this installation guide
2. Claims for missing parts once the product has been installed.
3. Repair costs for damage caused by foreign objects or substances.
4. Total loss of the product due to non-availability of parts.
5. Compensation for loss of use of the product or consequential loss of any kind.
6. Call out charges where no fault has been found with the appliance.
7. The cost of repair or replacement of pressure relief devices, showerheads, hoses, riser rails and/or wall brackets, isolating switches, electrical cable, fuses and/or circuit breakers or any other accessories installed at the same time.
8. The cost of routine maintenance, adjustments, overhaul modifications or loss or damage arising therefrom, including the cost of repairing damage, breakdown, malfunction caused by corrosion, furring,
9. Call out charges where the water supply cannot be isolated, this includes consequential losses arising from unserviceable supply valves.

Wet Rooms Direct

Customer Service: 01685 898110

Website: www.wetroomsdirect.net

E-mail: sales@wetroomsdirect.net

INCLUSIVE GRAB ***Riser Rail Kit***

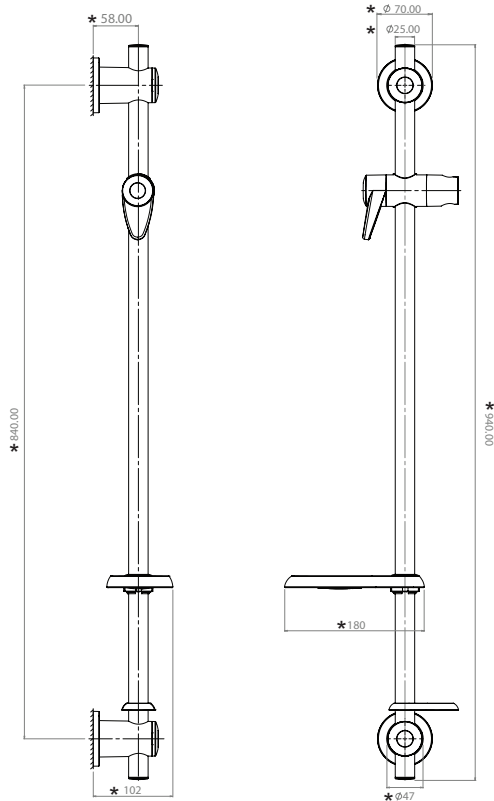

* All dimensions listed regarding the product and installation are approximate.
Please read the fitting instructions before proceeding.

Installation Instructions

INSTALLERS PLEASE NOTE THESE INSTRUCTIONS ARE TO BE LEFT WITH THE USER

FITTING THE RISER RAIL ASSEMBLY

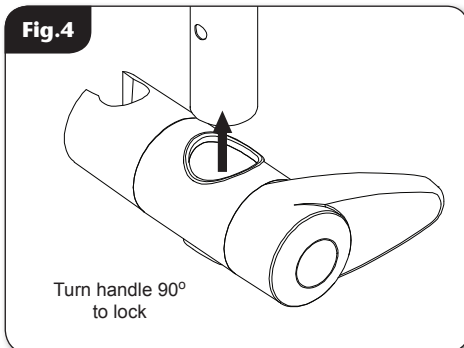
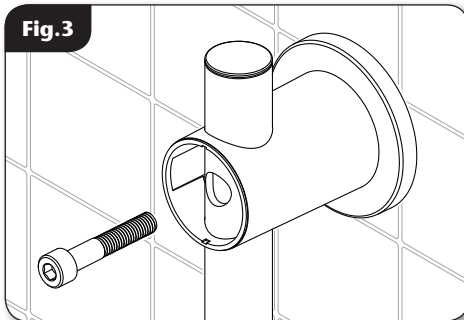
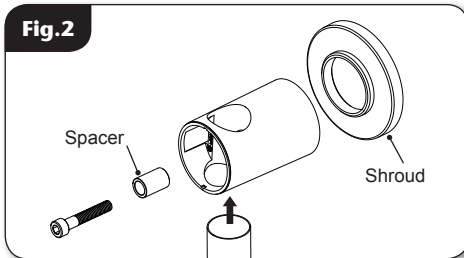
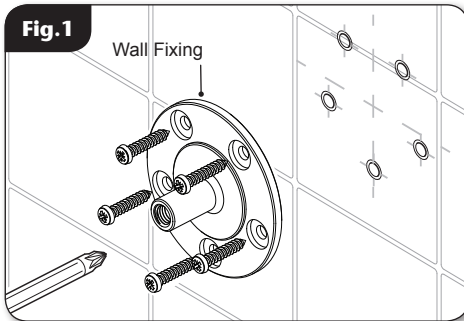

WARNING!

Check there are no hidden cables or pipes before drilling holes for wall plugs. Use great care when using power tools near water. The use of a residual current device (RCD) is recommended when using power tools.

When installed as instructed this kit can be used as a grab rail supporting up to 150kg. Suitable wall plugs and screws, for the type of wall, must be used to ensure the kit is secured properly to take the required loading.

For studded walls an appropriate wooden batten must be inserted in the wall to fix to. Do not rely on wall fixings through tile and plasterboard only for grab rail support.

Please note that the strength of the material being screwed into will heavily affect the loading strength of the rail.

- Place the riser rail to the wall and use both of the fixing holes to mark the position of the top and bottom wall fixings. Position the wall fixings in place and mark the locations of the holes to be drilled. Remove the wall fixings then drill and plug the wall.
- Replace the wall fixing to the wall and secure in place with 5 screws to ensure equal loading (**Fig.1**).

Note: Screws are not supplied with kit.

- Fit the shroud over the wall fixing and place the top bracket onto the shroud. Insert the spacer, slide the riser rail into the bracket and line up the fixing holes (**fig.2**).

Note: The larger of the two holes in the top and bottom of the riser rail should be facing outwards when the holes are aligned with the fixing hole in the bracket.

- Use the supplied M8 cap head screw to fix the riser rail and bracket to the wall fixing (**fig.3**).

FITTING THE RISER RAIL ASSEMBLY

- Fit the showerhead holder onto the riser rail. Turn the lever anti-clockwise to release the locking mechanism, then slide the holder onto the rail (**fig.4**). To secure the holder in place, turn the lever clockwise.
- Slide the soapdish and hose retainer onto the bottom of the riser rail, below the holder (**fig.5**).
- Fit the shroud and the bottom bracket, with spacer already inserted, onto the riser rail and screw to the bottom wall fixing.

Note: The screw should pass through the larger hole in the base of the riser rail (fig.6) and come to rest against the inner of the riser rail to stop it from turning within the bracket.

- Fit the end caps onto both brackets. The end caps will only fit one way. Fit the riser rail trims to both ends of the rail.

FITTING THE HOSE AND SHOWERHEAD

- Feed the flexible hose through the ring on the hose retainer. This is to comply with Water Regulations.
- Screw the flexible hose to the shower outlet and showerhead, making sure the supplied washers are in place at both ends of the flexible hose (**fig.7**).
- Place the showerhead into the holder and check that it fits correctly (**fig.8**).

Note: The holder is slightly tapered and the showerhead and hose will only fit from one direction.

IMPORTANT: It is the conical end of the hose which grips into the holder. The showerhead will not fit in the holder without the hose attached.

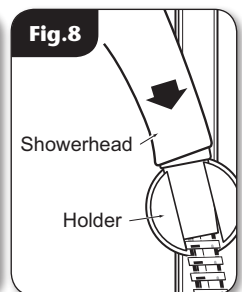
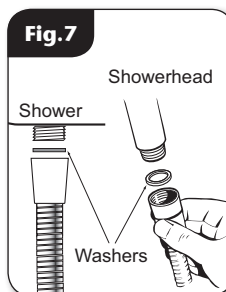
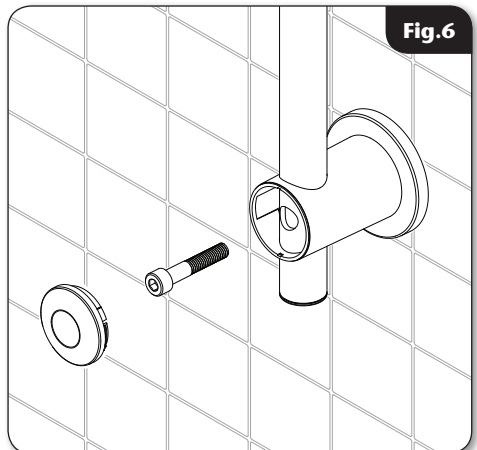
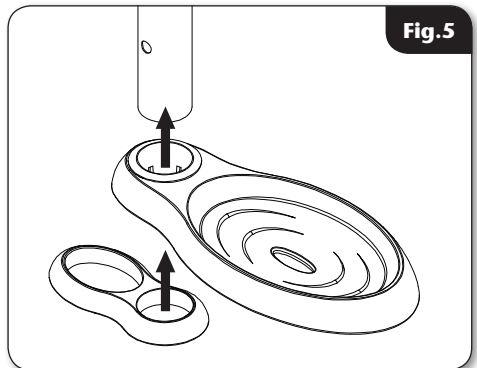

SPARE PARTS

Ref.	Description	Part number
-	Kit - <i>white/grey</i>	88900041
-	Kit - <i>chrome/grey</i>	88900042
1	Bracket Set* - <i>White</i>	83315380
	- Bracket (White)	
	- Cap (White)	
	- <i>Chrome</i>	83315390
	- Bracket (Chrome)	
	- Cap (Chrome)	
2	Wall Fixing Set	83315410
	- Wall Fixing	
	- M8 Cap Head Screw	
	- Spacer	
3	Bracket Cap - <i>white</i>	7054530
	- <i>chrome</i>	7054545
5	Riser Rail – 25 mm - <i>Stainless Steel</i>	88800038
6	S/Head Holder - <i>white/grey</i>	P84200110
	- <i>chrome/grey</i>	P84200120
7	Soap Dish	S86100380
8	Hose Retainer - <i>white</i>	7054532
	- <i>chrome</i>	7054546
9	Shroud	7054542

* Bracket Set for both white and chrome contains 2 of each component.

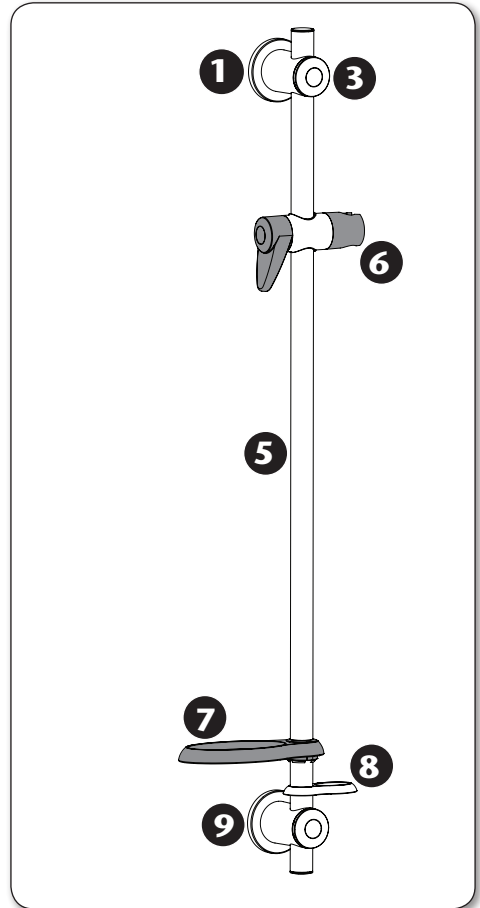

Please refer to shower installation and operating instructions for service details. E&OA.

8000 Series Showerhead

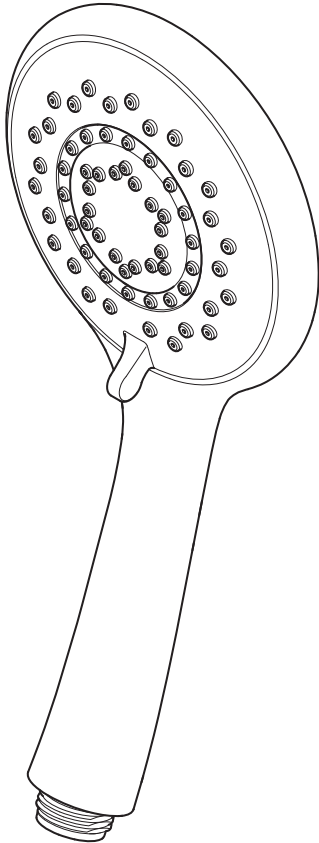

Maintenance Instructions

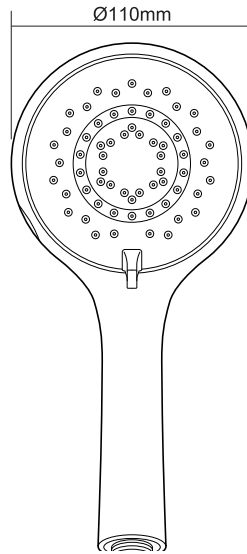
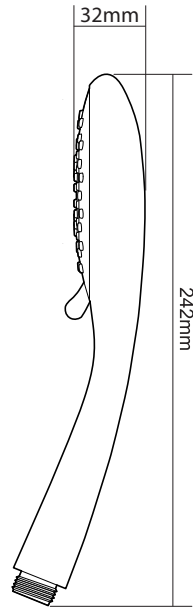

INSTALLERS PLEASE NOTE THESE INSTRUCTIONS ARE TO BE LEFT WITH THE USER

8000 SERIES SHOWERHEAD

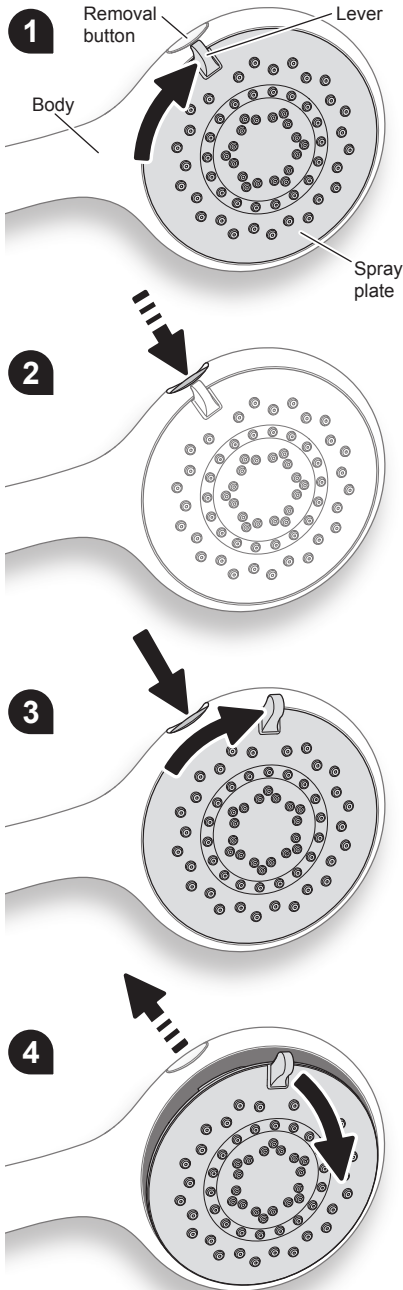

This instruction book covers the operation and cleaning of the showerhead.

SHOWERHEAD SPRAY POSITIONS

Five showerhead patterns are available.

Adjust the spray pattern by turning the lever on the showerhead in either direction until the desired pattern is obtained. These positions are located at 4, 5, 6, 7 and 8 o'clock, when the showerhead is in the vertical position.

REMOVING THE SPRAY PLATE

IMPORTANT: Before cleaning, turn off the unit at the mains supply to avoid the shower being accidentally switched on.

- 1 Rotate the spray plate clockwise until it reaches its 'stop' position facing the removal button.
- 2 Press and hold the removal button in.
- 3 With the removal button held in, rotate the face plate clockwise past the removal button until it stops.
- 4 Release the removal button and gently pull the face plate away from the body using the adjustment lever.

IMPORTANT

Should any difficulty arise when trying to remove the spray plate (image 4) **DO NOT** try to force it out of the body by hand, or by using tools such as a screwdriver. Reset the spray plate to the position shown in image 7 and repeat steps 1-4 as listed above.

DO NOT remove the inner plate (image 5). Removing this, **WILL** invalidate any product warranty.

8000 SERIES SHOWERHEAD

CLEANING

Triton recommends that all products are cleaned using warm, soapy water.

DO NOT use abrasive or aggressive chemical cleaning products as this may affect the product surface and finish and invalidate your guarantee.

NOTE: *The showerhead can be cleaned quickly by simply rubbing your fingers over the spray plate.*

IT IS IMPORTANT TO KEEP THE SHOWERHEAD CLEAN TO MAINTAIN THE PERFORMANCE OF THE SHOWER. The hardness of the water will determine the frequency of cleaning. For example, if the shower is used every day in a very hard water area, it may be necessary to clean the showerhead on a weekly basis.

REPLACING THE SPRAY PLATE

- 5 The spray plate and face plate **MUST** be aligned correctly for reinstallation. To align them correctly, please do the following:
 - a Ensure that the inner plate is turned fully clockwise until it stops. The alignment arrow position is approximately 9 o'clock, when the showerhead is in the vertical position.
 - b The lever **MUST** then be matched up with the arrows position to reinstall the spray plate correctly.

Should any difficulty arise when trying to refit the spray plate **DO NOT** try to force it back into position. Please make sure the arrow and lever positions are correct.

Once in place, the spray plate face should be gently pressed until its edges sit flush with the body.

- 6 Now installed into the body, start to turn the spray plate anti-clockwise.
- 7 To lock the plate back into the mechanism, the spray plate **MUST** be rotated fully anti-clockwise until it stops.

IMPORTANT: *The showerhead should be directed towards waste, and the shower switched on to ensure the spray plate is locked into the mechanism before use.*

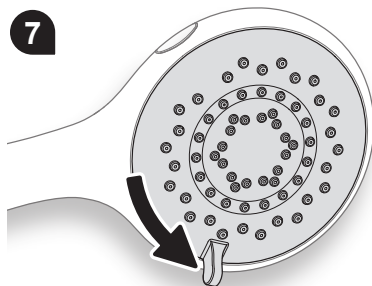
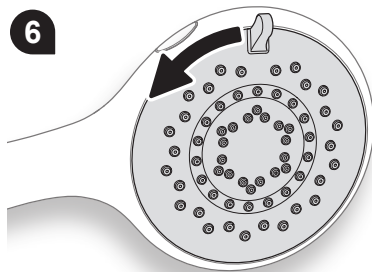
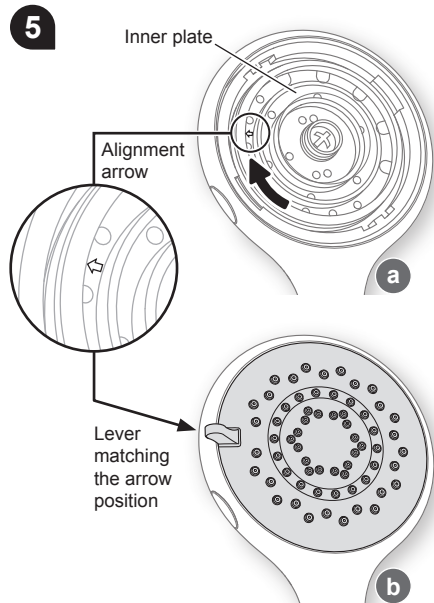

SPARE PARTS

Ref. Description **Part number**

1. 5 mode rub clean showerheads

SHOWER HEADS

(mixer showers only)

88500060WHITE MIXER
88500061CHROME MIXER
88500068SATIN MIXER

(electric showers only)

88500062.....INCLUSIVE WHT
88500069ELEC SATIN
88500070INCLUSIVE CHROME
88500074ELEC WHITE
88500075ELEC CHROME

2. Flow Regulator

FLOW REGULATORS

22011740.....4 L/MIN
22011750.....5 L/MIN
22011760.....6 L/MIN
22011610.....7 L/MIN
22011280.....8 L/MIN

